

FRONT ELEVATION

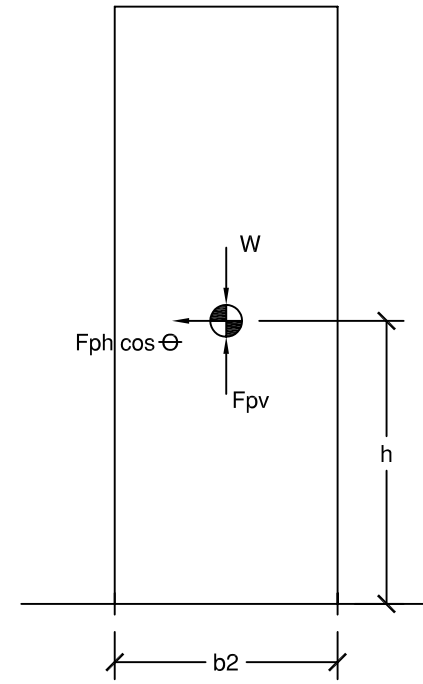

SIDE ELEVATION

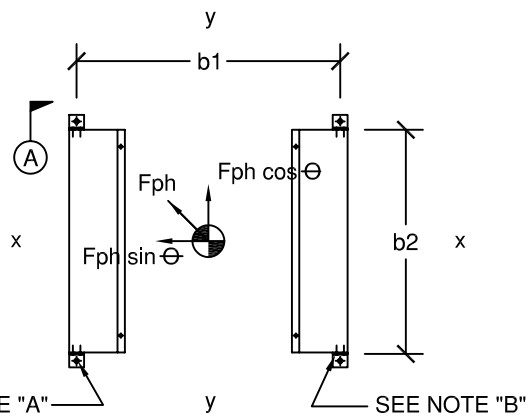

PLAN VIEW OF MOUNTING HOLE LOCATION

NOTE "A": (1) 1/2" DIA. HILTI KB-TZ PER ANGLE BRACKET W/ 2-5/8" EMBED.
 NOTE "B": (2) #12 SELF-TAPPING SCREW PER ANGLE @ 1" O.C.

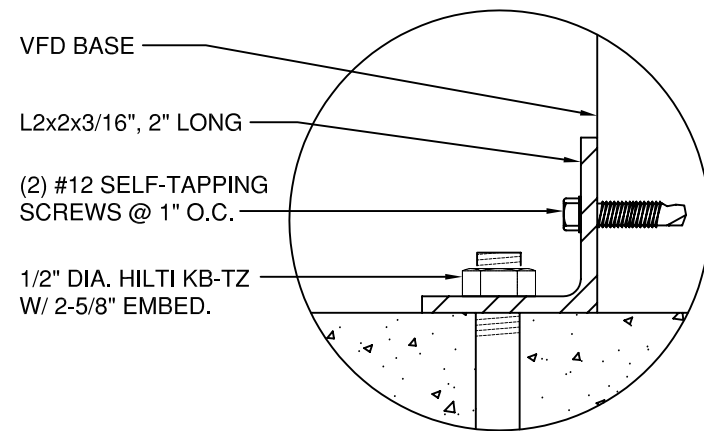

DETAIL A

Project:
Customer:
Date:



Tag:

A. PALMA
engineering

Equipment overturning calculations based on seismic load applied at a critical angle:

OPERATING WEIGHT: $W := 900 \cdot \text{lb}$

The following plan dimensions are as follows. Refer to attach plan view and elevation drawings.

$b1 := 34.00 \cdot \text{in}$

$b2 := 30.00 \cdot \text{in}$

$h_{cg} := 46.00 \cdot \text{in}$

$N := 4$ Number of angle brackets.

SEISMIC CRITERIA PER 2007 CBC & ASCE 7-05: Occupancy Category III, Site Class D

$S_s := 1.50$ Mapped spectral accelerations for short periods

$F_a := 1.00$ Site coefficient

$S_{MS} := F_a \cdot S_s$ MCE spectral response acceleration for short periods

$S_{DS} := \frac{2}{3} \cdot S_{MS}$ Spectral acceleration, short period

$z := 0.0$ Height in structure of point of attachment of component w/ respect to the base

$h := 1.0$ Average roof height of structure w/ respect to base

$I_p := 1.0$ Component importance factor

$a_p := 2.5$ Component amplification factor

$R_p := 6.0$ Component response modification factor

$$F_p := \frac{0.4 \cdot a_p \cdot S_{DS} \cdot W}{\frac{R_p}{I_p}} \cdot \left(1 + 2 \cdot \frac{z}{h} \right) \quad F_p = 150 \text{ lb}$$

shall not be greater than:

$$F_{pmax} := 1.6 \cdot W \cdot I_p \cdot S_{DS} \quad F_{pmax} = 1440 \text{ lb}$$

and shall not be less than:

$$F_{pmin} := 0.3 \cdot W \cdot I_p \cdot S_{DS} \quad F_{pmin} = 270 \text{ lb} \quad \text{Governs!}$$

Project:
Customer:
Date:



Tag:

A. PALMA
engineering

$$F_{ph} := \frac{F_{pmin}}{1.4} \quad F_{ph} = 193 \text{ lb}$$

Vertical seismic load:

$$F_{pv} := 0.2 \cdot S_{DS} \cdot W \quad F_{pv} = 180 \text{ lb}$$

Consider the load applied in any horizontal direction. Refer to elevation drawing attached.

$$\text{The Transverse Component} = F_{ph} \cos(\theta)$$

$$\text{The Longitudinal Component} = F_{ph} \sin(\theta)$$

The uplift load on angle no. 4:

$$P_t = \frac{0.9W - F_{pv}}{N} - \frac{F_{ph} \cdot \cos(\theta) \cdot h_{cg} \cdot \frac{b2}{2}}{I_{yy}} - \frac{F_{ph} \cdot \sin(\theta) \cdot h_{cg} \cdot \frac{b1}{2}}{I_{xx}}$$

The compressive load on angle no. 1:

$$P_c = \frac{0.9W + F_{pv}}{N} - \frac{F_{ph} \cdot \cos(\theta) \cdot h_{cg} \cdot \frac{b2}{2}}{I_{yy}} + \frac{F_{ph} \cdot \sin(\theta) \cdot h_{cg} \cdot \frac{b1}{2}}{I_{xx}}$$

where,

$$I_{xx} := \frac{N \cdot (N + 2) \cdot b1^2}{12 \cdot (N - 2)}$$

$$I_{xx} = 1156 \text{ in}^2$$

$$I_{yy} := \frac{N \cdot b2^2}{4}$$

$$I_{yy} = 900 \text{ in}^2$$

To maximize the values,

$$\frac{dP_t}{d\theta} = 0 \quad \text{and} \quad \frac{dP_c}{d\theta} = 0$$

Project:
Customer:
Date:



Tag:

A. PALMA
engineering

will yield a condition:

$$\theta := \text{atan}\left(\frac{I_{yy} \cdot b1}{I_{xx} \cdot b2}\right)$$

$$\theta = 41.42 \text{ deg}$$

CHECK ANCHOR ATTACHMENTS

Maximum Tension per angle:

$$P_t := \frac{0.9W - F_{pv}}{N} - \frac{F_{ph} \cdot \cos(\theta) \cdot h_{cg} \cdot \frac{b2}{2}}{I_{yy}} - \frac{F_{ph} \cdot \sin(\theta) \cdot h_{cg} \cdot \frac{b1}{2}}{I_{xx}}$$

$$P_t = -40 \text{ lb} \quad \text{UPLIFT}$$

Maximum Shear per angle:

$$P_s := \frac{F_{ph}}{N}$$

$$P_s = 48 \text{ lb}$$

Allowable load for #12 self tapping screw attached to min. 18 ga. enclosure per ICBO Report ER-5202:

$$n_s := 2 \quad \text{Number of screws per angle bracket.}$$

$$T_s := \frac{P_s}{n_s} \quad \text{Tension per screw.}$$

$$V_s := \frac{|P_s|}{n_s} \quad \text{Shear per screw.}$$

$$V_{\text{allow}} := 326 \cdot \text{lb} \quad > \quad V_s = 24 \text{ lb} \quad \text{Okay!}$$

$$T_{\text{allow}} := 141 \cdot \text{lb} \quad > \quad T_s = 24 \text{ lb} \quad \text{Okay!}$$

Project:
Customer:
Date:



Tag:

A. PALMA
engineering

Consider L2"x2"x3/16", 2" long:

$$\begin{aligned} b &:= 2.00\text{in} && \text{Length of angle.} \\ d &:= 0.1875\text{in} && \text{Thickness of angle.} \\ w_a &:= 2.00\text{in} && \text{Width of angle.} \\ h_a &:= 2.00\text{in} && \text{Height of angle.} \\ M &:= P_s \cdot h_a && \text{Max. bending moment.} \\ s &:= \frac{b \cdot d^2}{6} && \text{Section modulus.} \\ f_b &:= \frac{M}{s} && \text{Bending stress.} \\ F_y &:= 36000\text{lb} \cdot \text{in}^{-2} && \text{Yield stress.} \\ F_b &:= 0.66 \cdot F_y && \text{Allowable stress.} \\ F_b = 23760\text{ lb} \cdot \text{in}^{-2} &> & f_b = 8229\text{ lb} \cdot \text{in}^{-2} & \quad \underline{\text{Okay!}} \end{aligned}$$

Transfer load to anchors:

$$\begin{aligned} T_a &:= \frac{|P_t| \cdot w_a + P_s \cdot h_a}{\frac{w_a}{2}} && \text{Tension per anchor.} \\ T_a &= 176\text{ lb} \\ V_a &:= P_s && \text{Shear per anchor.} \\ V_a &= 48\text{ lb} \end{aligned}$$

Project:
Customer:
Date:



Tag:

A. PALMA
engineering

CHECK ANCHORS: Calculation per Tables 9 & 10 in ICC ES Report ESR-1917.

Consider 1/2" dia. Carbon Steel Hilti KB-TZ anchor w/ 2-5/8" embedment into 3000psi normal weight concrete.

Assumptions: _____

Edge Distance = 5.5" Minimum

Anchor Spacing = 5.75" Minimum

Concrete Thickness = 4.0" Minimum

CHECK COMBINED LOADING

$T_{allow} := 1167lb$

$V_{allow} := 2839lb$

$$\frac{T_a}{T_{allow}} + \frac{V_a}{V_{allow}} = 0.17 < 1.2 \quad \text{Okay!}$$